

# 1995 STANDARD FOR PROTECTIVE HEADGEAR

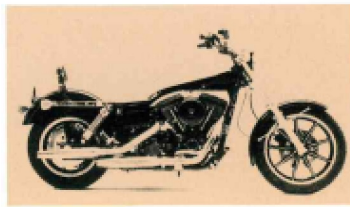

*For Use With Motorcycles  
and Other Motorized Vehicles*



1995 STANDARD FOR PROTECTIVE HEADGEAR  
For Use With Motorcycles and Other Motorized Vehicles

***Special Note to Helmet Users***

There are four reasons for you to be interested in this Standard:

1. The use of motorcycles and other motorized vehicles imposes risks of death or permanent impairment due to head injury.
2. The proper use of protective helmets can minimize the risk of death or permanent impairment.
3. The protective capacity of a helmet is difficult to measure, particularly at the time of purchase or use.
4. Snell certification backed by ongoing random sample testing identifies those helmet models providing and maintaining the highest levels of head protection.

Four of the most critical elements affecting a helmet's protective properties are:

1. Impact management - how well the helmet protects against collisions with large objects.
2. Helmet positional stability - whether the helmet will be in place, on the head, when it's needed.
3. Retention system strength - whether the chinstraps are sufficiently strong to hold the helmet throughout a head impact.
4. Extent of Protection - the area of the head protected by the helmet.

This Standard describes simple tests for all four of these items. However, the tests for the second item, helmet stability, of necessity presume that the helmet is well matched to the wearer's head and that it has been carefully adjusted to obtain the best fit possible.

Unless you take similar care in the selection and fitting of your own helmet, you may not obtain the level of protection that current headgear can provide.

The Foundation recommends the simple, straightforward procedure recommended to consumers by most helmet manufacturers:

Position the helmet on your head so that it sits low on your forehead; if you can't see the edge of the brim at the extreme upper range of your vision, the helmet is probably out of place. Adjust the retention system so that when in use, it will hold the helmet firmly in place. This positioning and adjusting should be repeated to obtain the very best result possible. The procedure initially may be time consuming. Take the time.

Try to remove the helmet without undoing the retention system closures. If the helmet comes off or shifts over your eyes, readjust and try again. If no adjustment seems to work, this helmet is not for you; try another.

This procedure is also the basis of the test for helmet stability described in this Standard. This test performs the same steps but uses standard headforms.

However, you must still perform this procedure for yourself when buying a helmet and every time you wear a helmet. Only in this way will you be able to make all the proper adjustments to get the best fit possible. Furthermore, your test on your own head will be an improvement on ours; you will determine whether the helmet is appropriate for you personally.

There are several other important aspects of helmets to consider. Full face helmets provide a measure of protection from facial injuries. The external shell of these helmets includes a rigid "chin" bar that passes from left to right over the lower part of the face. The Foundation has devised special tests for the chin bars of full face helmets.

Some helmets come with a separate structure that bolts to the helmet in order to cover the lower part of the face. These removable chin bars are often intended to deflect small stones and debris encountered in some motorcycle sports and may not be effective facial protection in falls and accidents. The Foundation does not test removable chin bars and considers any headgear equipped with them to be an open face helmet.

If a full face helmet is equipped with a face shield, it may also provide a measure of eye protection. The Foundation tests the face shields of full face helmets for particle penetration resistance. Face shields provided with open face helmets generally do not provide the same levels of eye protection and, for that reason are not considered.

The shells of both open and full face helmets should also provide a measure of protection from penetration. The Foundation tests the shells both full and open face helmets for penetration resistance.

Effective headgear must be removable. Paramedics and other emergency personnel must be able to quickly remove headgear from accident victims in order to check for vital signs and to perform emergency procedures. The Foundation has devised tests and criteria for helmet removability.

The Foundation tests helmets for visual field. The helmet must provide a minimum range of vision appropriate to its use as measured on standard headforms. Most Snell certified helmets will meet the requirements stated in this Standard and considered appropriate for street use. However, the Foundation may also certify headgear with much more restricted visual fields for use only in carefully controlled competitive environments. Such headgear will include warning labels identifying them as appropriate only for certain activities.

Be absolutely certain that your helmet is appropriate for your intended uses. Furthermore, since the range of vision you obtain may vary considerably from our

measurement, be absolutely certain that the helmet and face shield permit you adequate vision.

Finally, there are several important factors which the Foundation does not consider directly but which bear on the effectiveness of protective helmets. Be certain your helmet is wearable, that is that it's comfortable and adequately ventilated when worn for prolonged periods. Few people will wear an uncomfortable helmet. A helmet that is not worn won't protect anyone.

Check for high visibility. Bright colors and reflective patches will make you more visible to others and therefore less likely to be involved in a collision.

Finally, check the style of the helmet. Unless you're willing to be seen in the helmet, you will not wear it. Select a helmet you know you'll wear.

## ***FOREWORD***

In a motorcycle accident, the rider may suffer injury or death. Helmets on the market today offer varying degrees of protection, but the consumer has little basis for judging the relative effectiveness of a given model. This Standard presents a rational means for differentiating between helmets which meet specified standards for impact (crash) protection and retention system strength and those which do not.

The Snell Foundation urges that protective helmets be required for all individuals participating in supervised racing events and encourages the general public to wear helmets which meet appropriate performance standards<sup>1</sup>.

---

<sup>1</sup>The Foundation has also published Standards for headgear used in bicycling, non-motorized sports, automobile racing, and equestrian activities. Copies of these Standards are available on request.

This 1995 Standard establishes performance characteristics suitable for motorcycling and for use with other open motorized vehicles in which the driver and passengers may not be enclosed such as boats, carts, all-terrain vehicles and snowmobiles. **This Standard does not establish construction and material specifications. The Foundation does not recommend specific materials or designs.** Manufacturers voluntarily submit helmets to be tested to this Standard and if the submitted helmets pass, a certification is issued.

The Foundation will make available the identity of those products which have been Snell certified but will not attempt to rank those products according to performance nor to any other criteria. Neither does the Foundation distinguish between the needs of participants in competitive events and those of the general public.

**All of the requirements described herein, including both initial certification and random sample testing, are an integral part of this Standard. No helmet can satisfy the Standard unless it is subject to both certification and random sample testing by the Foundation.**

**Snell certification for protective headgear requires a specific contractual agreement between the primary headgear manufacturer and the Foundation. Certification procedures may be obtained upon application to the Foundation.**

**SNELL MEMORIAL FOUNDATION is a registered certification mark and M-95 is a certification mark of the Snell Memorial Foundation.**

## ***INTRODUCTION***

This Standard addresses the problem of protecting the head from direct impact with surfaces or objects that might be encountered in a motorcycling accident. The Standard prescribes direct measures of several factors bearing on a helmet's ability to protect the

head as well as its general serviceability as motorcyclist headgear. Thus, this Standard is directed towards the kinds of performance bearing on head protection that may not readily be discernable by even knowledgeable consumers at the time of purchase.

Some of these performance requirements have been expressed in terms of limitations on the various components and features of the single general helmet configuration currently available. These expressions have been used only for the sake of clarity and should not be misinterpreted as requiring specific configurations or materials. As newer helmet technologies appear, these limitations will be re-examined and, perhaps, restated.

A motorcycle helmet consists generally of a rigid head covering and a retention system composed of flexible straps and hardware. The rigid covering consists of a stiff outer shell and a crushable liner. The stiff outer shell protects by its capacity to spread a concentrated load at its outer surface over a larger area of the liner and the wearer's head. The crushable liner protects the head from direct impact by its capacity to manage impact energy.

The retention system holds the headgear in position throughout normal usage and especially during falls and accidents. This Standard applies two different tests to the retention system. The first of these tests for stability by fitting the headgear to a standard headform and then attempting to displace it by applying tangential shock loadings. The second tests retention system strength by applying a shock load to the system components through a simulated chin.

The quality of the fit and the care taken with the adjustments are absolutely critical elements in these tests. **The manufacturer must provide suitable guidance so that the wearer will be able to select and adjust headgear to obtain the necessary quality of fit and positional stability.**

The capacity for impact protection is determined by direct measurement of the shock delivered through the helmet to a headform when the helmeted headform is dropped in a specified manner onto any of three unyielding anvils.

Most motorcycle helmets are intended to accommodate a range of head sizes and shapes. Various thicknesses of resilient lining material are sometimes placed within otherwise identical helmets during production or during fitting to configure the helmet to several different ranges of head size. This resilient padding does not significantly affect the way the helmet absorbs and attenuates impact and is not directly addressed in this Standard.

The helmet must also resist penetration by projectiles such as parts of exploding engines or other damaged mechanical assemblies. This capacity is tested by placing the helmet on a headform and dropping a metal cone of specified mass and geometry onto the shell. The tip of this cone must not penetrate to the headform.

Similarly, the helmets must resist chemical attack by solvents and petrochemicals associated with motorsports. This capacity may be tested by applying a solvent mix before further conditioning and testing.

Full face helmets provide a measure of facial protection in addition to the impact protection generally sought. The principle feature of a full face helmet is a chin bar that extends forward to cover the jaw area converting the facial opening into a visual port. Frequently, a face shield is also provided so that the wearer's face is completely covered.

In order to be considered a full face helmet, the chin bar must be an integral part of the helmet structure. The Standard then tests the rigidity of the chin bar by dropping a weight onto it at a specified velocity so as to attempt to force the chin bar toward the interior of the helmet. The chin bar must not deflect more than a specified amount.



If a face shield is provided with a full face helmet, then this face shield must resist penetration by small particles. A sharp lead pellet of a specified weight is directed into the face shield at a specified velocity. The pellet must not penetrate into the helmet interior.

This Standard also includes a test intended to determine whether the headgear may be removed from a living but perhaps unconscious accident victim quickly, easily and reliably in spite of any damage the headgear might reasonably be expected to sustain. Traditional helmet architectures have satisfied this requirement so readily that many Standards including previous Snell Foundation Standards have not mentioned it. Even so, it is unthinkable that a headgear might protect its wearer in an accident only to thwart attempts at rescue afterward.

Inadequate ventilation may render a helmet unwearable in hot climates, especially if the helmet is full faced. This Standard limits the diameter of ventilation holes in the helmet shell but makes no direct demands on either the quantity or quality of air flow to the wearer.

Other general features of motorcycle helmets may include eyeshades and accommodations for goggles, and visibility enhancements such as bright colors and reflective surfaces. These features all deal with matters of safety and comfort that are not directly addressed in this Standard but which merit the consideration of wearers as well as manufacturers.

Although helmet use has been shown to reduce the risk of head injuries significantly, there are limits to a helmet's protective capability. No helmet can protect the wearer against all foreseeable accidents. Therefore injury may occur in accidents which exceed the protective capability of any helmet including even those helmets meeting the requirements of this Standard.

A helmet's protective capability may be exhausted protecting the wearer in an accident. Helmets are constructed so that the energy of a blow is managed by the helmet,

causing its partial destruction. The damage may not be readily apparent and the Foundation strongly recommends that a helmet involved in an accident be returned to the manufacturer for complete inspection. If it is not possible to do so, the helmet should always be destroyed and replaced.

Finally, the protective capability may diminish over time. Some helmets are made of materials which deteriorate with age and therefore have a limited life span. At the present time, the Foundation recommends that motorcycle helmets be replaced after five (5) years, or less if the manufacturer so recommends.

## ***CONSTRUCTION***

### **A. General**

The assembled helmet shall have smooth external and internal surfaces. Any feature projecting more than 7 mm beyond the outer surface must readily break away; all other projections on the outer surface shall be smoothly faired and offer minimal frictional resistance to tangential impact forces. Rivets and similar projections into the helmet interior must offer no laceration or puncture hazard. Restraint clips may be used at the rear or on the side of the helmet. The helmet shall provide as nearly uniform impact protection over the entire protected area as is possible.

If the absence of any detachable component of the helmet does not prevent its being worn, then this absence must not compromise either the retention system or the impact protection. If any part of the helmet detaches during testing, it must offer no laceration or puncture hazard nor reduce the coverage of the head.

If the manufacturer provides add-ons such as visors, face shields and neck curtains with the helmet, these add-ons must neither lessen the protective capability of the basic helmet nor create a direct hazard for the wearer.

## **B. Shell**

Shell ventilation holes, if used, shall not exceed 13 mm in diameter. If rivets are used, the heads shall not have sharp edges and shall not project more than two mm from the outer surface of the helmet.

## **C. Materials**

Ideally, materials used in the manufacture of the helmet should be of durable quality and not be harmed by exposure to sun, rain, dust, vibration, sweat or products applied to the skin or hair. Similarly, the materials should not degrade due to temperature extremes likely to be encountered in routine storage or transportation.

Materials which are known to cause skin irritation or are conducive to disease shall not be used for the parts which contact the skin. Materials that support the growth of fungi or algae shall not be used. Lining materials, if used, may be detachable for the purpose of washing so long as their absence does not degrade the protective capabilities of the helmet.

## **D. Finish**

All edges of the helmet shall be smoothed and rounded with no metallic parts or other rigid projections on the inside of the shell that might injure the wearer's head in the event of impact.

## **E. Retention System**

The retention system shall be designed so as to discourage misuse. That is, of all the ways in which the retention system might be used, the design use shall be the simplest and quickest to implement. Helmets shall not be fitted with "non-essential" features which, if

misused, can degrade the performance. Quick release buckles, if used, shall not be able to be released inadvertently.

#### **F. Peripheral Vision**

The helmet shall provide peripheral visual clearance as measured using a reference headform appropriate to the size of the helmet. This peripheral vision includes a horizontal clearance of at least 210°, an upward clearance of at least 7° and a downward clearance of at least 30°. However, this downward clearance makes specific allowance for breath deflectors. These clearances are described in terms of planes fixed in the reference headforms.

Some competitive applications may require helmets with more restricted visual fields. When justified, special addenda to this Standard will define reduced visual fields, the procedures for determining whether a helmet satisfies the requirement and the additional labelling requirements warning that the headgear may be appropriate only for certain uses.

#### ***QUALIFICATIONS FOR CERTIFICATION***

For qualification testing, helmets shall be in the same condition as those offered for sale. No helmet or component which has been subjected to any tests described in this Standard shall be offered for sale after testing. A total of five (5) complete helmets must be submitted by the manufacturer for a certification test program for each distinct structural configuration of the models offered for sale. Four of these samples will be destroyed in testing, the fifth shall be retained for comparison and reference.

#### ***MODIFICATIONS***

Cosmetic changes to certified headgear are permissible. Such changes are generally limited to marking or trimming the headgear with manufacturer approved paint or tape.

Otherwise, modification of certified headgear creates new headgear which will not have the confidence and certification of the Foundation until samples have been submitted and evaluated. Manufacturers must not place the Foundation's certification label in any modified headgear for which they have not received written permission.

After-market modifiers of such certified headgear should be aware that any structural modification may adversely affect a helmet's protective capability and therefore invalidate the certification.

### ***RANDOM SAMPLE TESTING***

In addition to the certification testing, the Foundation will routinely obtain and test samples of previously certified models. These samples will be selected from among those stocks intended for retail sale to consumers. In this manner, the Foundation will attempt to ensure that the helmets made available to the public continue to meet the performance requirements of this Standard.

In cases where helmets are provided directly to users and do not pass through a normal sales distribution system, the Foundation will set up alternative procedures to monitor certified products. Specifically, if helmets are provided directly to teams or individuals for use in organized events, the Foundation must have access to the helmets for spot checking and non-destructive evaluation.

### ***LABELING AND MARKING***

Each helmet shall have durable, visible and legible labeling identifying the manufacturer, the month and year of manufacture, the model and the size. Labeling shall

be uncoded and either in English or a language common to the area where the helmets are to be distributed. The headgear shall also be labeled to the following effect:

1. No helmet can protect the wearer against all foreseeable impacts. However, for maximum protection, the helmet must be of good fit and the retention system must be securely fastened to retain the helmet. The helmet, when fitted and fastened, shall not be removed easily.
2. This helmet is so constructed that the energy of an impact may be absorbed through its partial destruction, though damage may not be visible. If it suffers an impact, it must either be returned to the manufacturer for inspection or be destroyed and replaced.
3. Certified as a full face helmet. (or) Certified as an open face helmet. (as appropriate.)

If any of the helmet components are sensitive to common solvents, adhesives, paints or cleansers; the helmet must also bear labels to the following effect:

This helmet can be seriously damaged by some common substances without visible damage. Apply only the following: (Recommended cleaning agents, paints, adhesives and the like) as appropriate.

If the helmet model was certified according to a special addendum to this standard, each helmet shall also include the warning labels required by that addendum.

Each helmet shall also include one of the Foundation's serialized certification labels. The Snell certification label shall be placed either inside or on the outside of the helmet, as appropriate, in such a way that it cannot be removed intact.

The registered trademark (certification label) of the Snell Memorial Foundation may be used by the manufacturer only under license from the Snell Memorial Foundation. The specifics of licensure may be obtained from the Foundation.

## ***EXTENT OF PROTECTION***

The extent of protection corresponds to that region of the head for which protection is sought. This region is defined according to the geometry of four reference headforms: 'A', 'E', 'J', 'M' and 'O' which are described in International Standards Organization (ISO) Draft Standard ISO DIS 6220-1983.

There are a number of planes fixed in the geometry of these headforms as shown in Figure 1. This description of the extent of protection uses the ISO definitions of the basic plane, the longitudinal plane, the transverse plane and the reference plane. Since the reference plane used in conjunction with earlier Snell Standards does not correspond at all to the definition for the ISO reference plane, a new  $S_0$  plane has been defined. Other planes have also been defined strictly for convenience and clarity.

The basic plane corresponds to the anatomical plane (Frankfort plane) that includes the auditory meatuses and the inferior orbital rims. The longitudinal or midsagittal plane is perpendicular to the basic plane and is the plane of symmetry dividing the right half of the headform from the left. The transverse or coronal plane is perpendicular to both the longitudinal and basic planes. It corresponds to the anatomical plane that contains the two auditory meatuses and divides the front from the rear portions of the head. The reference plane is parallel to the basic plane and lies above it at a distance determined by the size of the headform: 24 mm, 26 mm, 27.5 mm, 29 mm and 30 mm for the 'A' through 'O' headforms respectively.

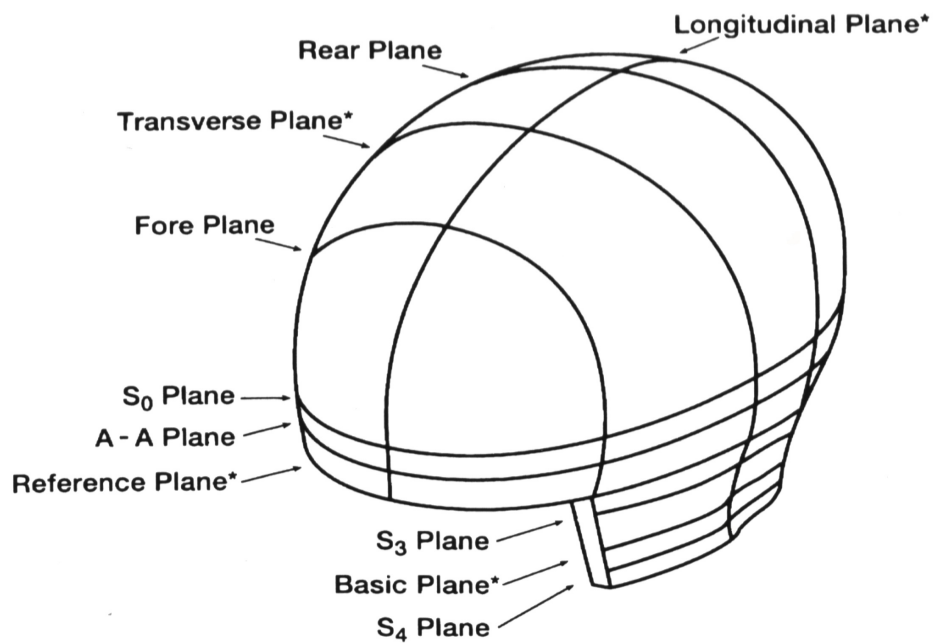

figure 1.

### ISO Headform ---- ISO DIS 6220-1983

These four planes are all well known entities. The remaining planes, however, have been defined purely for the purposes of this Standard. The  $S_0$  plane is parallel to the basic plane and lies above it at a distance determined by the size of the headform: 46.8 mm, 50 mm, 53 mm, 55.2 mm and 57.2 mm for the 'A' through 'O' headforms respectively.



The  $S_3$  plane is parallel to the  $S_0$  plane and the basic plane and lies between them at a distance of 26.1 mm, 28.2 mm, 30 mm, 31.5 mm and 32.2 mm below the  $S_0$  plane for the 'A' through 'O' headforms respectively. The  $S_4$  plane is also parallel to the  $S_0$  plane and lies below it a distance of 52.2 mm, 56.4 mm, 60 mm, 63 mm and 64.5 mm for the 'A' through 'O' headforms respectively.

The rear plane divides the rear third of the head from the front two thirds. It is parallel to the transverse plane and lies at a given distance behind the point where the reference plane and longitudinal planes intersect with the front surface of the headform. The distance from this point, hereafter called the reference point, is determined by the size of the headform: 128.6 mm, 139 mm, 148.4 mm, 155.8 mm and 161.5 mm for the 'A' through 'O' headforms respectively.

The fore plane is also parallel to the transverse plane. It lies behind the point where the reference plane and longitudinal planes intersect with the front surface of the headform. The distance from this point, hereafter called the reference point, is determined by the size of the headform: 39 mm, 42.2 mm, 45.2 mm, 47.4 mm and 49.2 mm mm for the 'A' through 'O' headforms respectively.

The extent of protection provided by the helmet must include the entire region above the  $S_0$  plane and forward of the fore plane, the entire region above the  $S_3$  plane and between the fore and rear planes and the entire region above the  $S_4$  plane and behind the rear plane. (See Figure 2.)

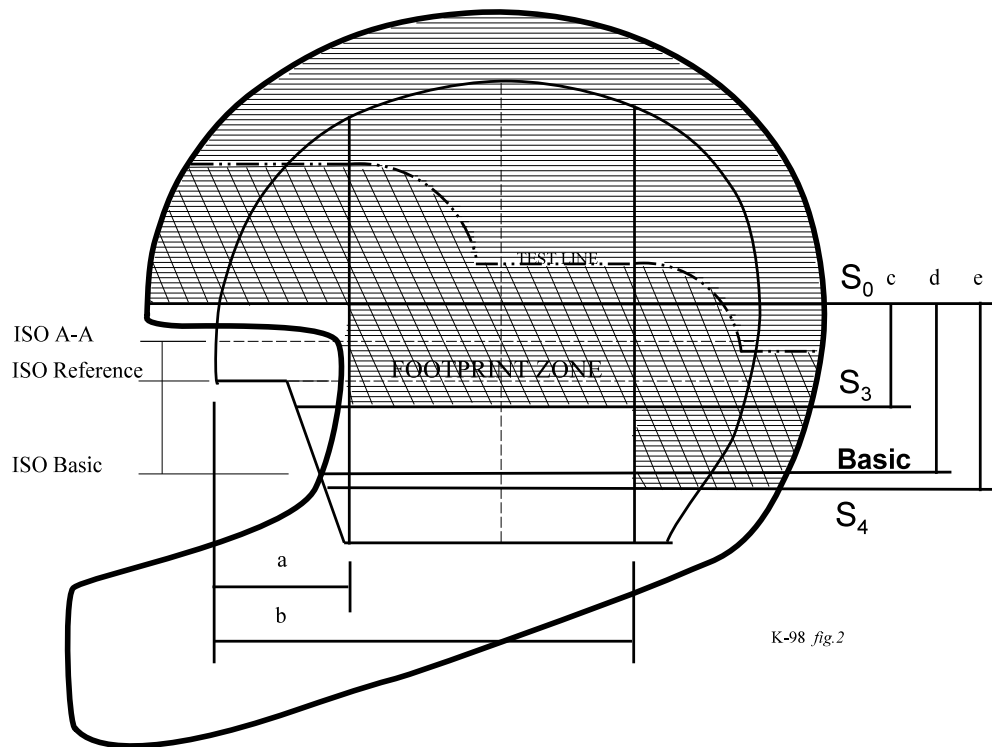

Figure 2.

### Extent of Protection

Headform	a	b	c	d	e
ISO A	39.0	128.6	26.1	46.8	52.2
ISO E	42.2	139.0	28.2	50.0	56.4
ISO J	45.2	148.4	30.0	53.0	60.0
ISO M	47.4	155.8	31.5	55.2	63.0
ISO O	49.2	161.5	32.2	57.2	64.5

Units of measure are in millimeters.

### TESTING

#### A. Helmet Positioning

Each helmet will be positioned on the appropriate headforms for testing according to the helmet positioning indices specified. If the manufacturer fails to provide positioning

information with certification samples, the helmets will be positioned according to the best judgement of the Foundation's technical personnel. If the helmets meet certification requirements, the helmet positioning indices will be those used in all future testing.

These helmet positioning indices represent distances on the headform measured from the basic plane along the intersection with the longitudinal plane to the lower edge of the helmet.

Helmet positioning indices will be assigned for all headform sizes appropriate to the headgear. Each headgear could conceivably require four helmet positioning indices, one each for the 'A', 'E', 'J' and 'M' headforms.

## **B. Inspection**

Each helmet will be inspected for the required labels and for compliance with the general limitations made on structure. The weight and various circumferences will be recorded for comparison with other samples of the same make and model.

Some helmets may incorporate innovations and other features not anticipated by this Standard but which raise concerns about the safety and effectiveness of the headgear. These will be referred to members of the Foundation's Board of Directors for evaluation. Any feature found to reduce the protective capacity of the headgear, whether explicitly mentioned in this Standard or not, will be a cause for rejection.

## **C. Marking**

The helmet is placed upon the largest appropriate ISO headform, positioned according to the apposite helmet positioning index and held in place with an applied force

of 50 newtons (11.25 lbs). The intersections of the shell with the various defined planes are then traced onto the outer surface of the helmet in the following manner:

The level of the  $S_0$  plane is marked on that portion of the helmet in front of the fore plane. The level of the  $S_3$  plane is marked on that portion lying between the fore and rear planes. The level of the  $S_4$  plane is marked on that portion behind the rear plane. Finally, line segments along the fore plane are marked to join the  $S_0$  and  $S_3$  planes and, similarly, line segments along the rear plane are marked to join the  $S_3$  and  $S_4$  planes.

These lines enclose the top of the helmet and are the boundary of the required extent of protection. However, it shall not be a cause for rejection if parts of this boundary fall below the edge of the helmet. A test line shall be drawn within this extent of protection so that it is 50 mm from the closest point on the boundary. (See Figure 2)

If identical helmets are to be configured with different thicknesses of comfort padding to accommodate different ranges of head size, the required extent of protection marked on the test samples shall include the required extent of protection for each different configuration as marked on the largest headform appropriate for each. That is: the helmet must meet all the requirements of this Standard in each of the intended configurations.

#### **D. Peripheral Vision**

Helmets certified to a special addendum to this standard and bearing the warning labels specified in the addendum will not be subjected to the following procedures and criteria for evaluating clearances for vision. However, the procedures and criteria specified in the addendum will be applied instead.

The clearance for peripheral vision will be checked by placing the helmet on each appropriate ISO headform, positioning it according to the apposite helmet positioning index

and holding it in place with a force of 50 newtons. The clearance must include the following solid angles to the front of the headform:

1. The upward visual clearance.
2. The lateral visual clearance.
3. The downward visual clearance except for the breath deflector allowance.

The upward visual clearance is the solid angle bounded by the reference plane of the headform and a second plane tilted  $7^\circ$  up from the reference plane. This second plane intersects the reference plane at two points on the front surface of the headform that are 31 mm to the right and left of the longitudinal plane as shown in figure 3.

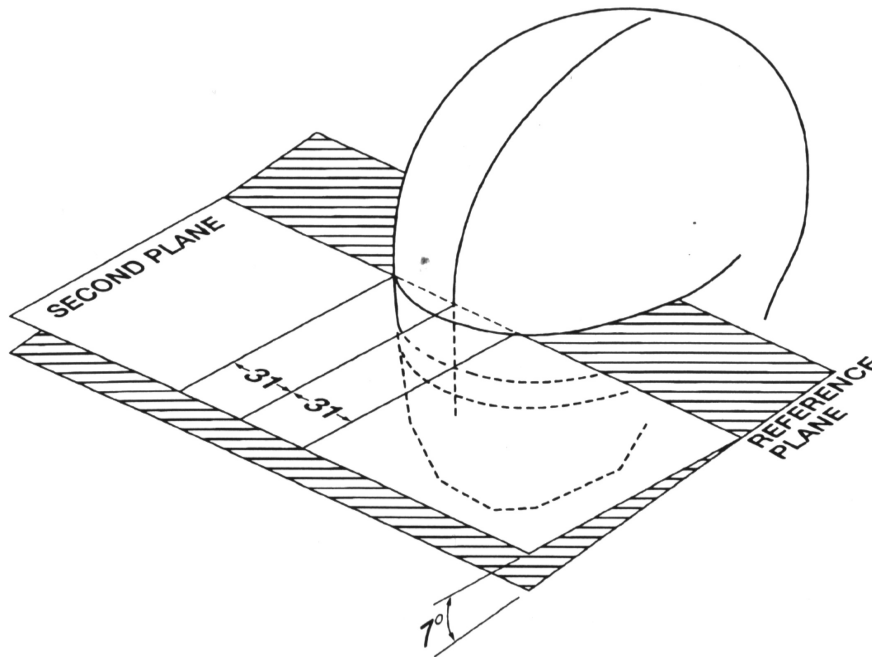

figure 3.

### Upward Visual Clearance

The lateral visual clearance, as shown in figure 4, is the solid angle bounded by the reference plane, the  $S_4$  plane and two more planes that are perpendicular to the reference

plane and that contain the point on the front of the headform where the longitudinal and reference planes intersect. One of these two planes forms an angle of  $105^\circ$  with the longitudinal plane and lies to the left of the headform. The other forms the same angle to the right of the headform.

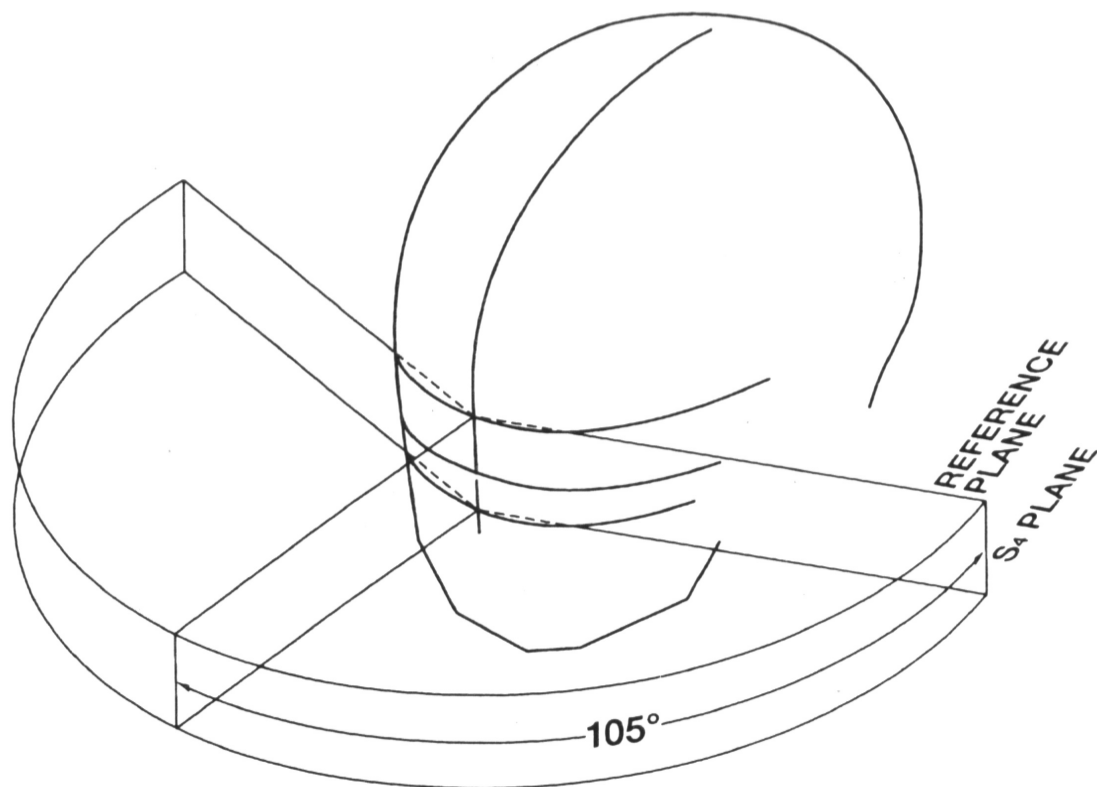

figure 4.

### Lateral Visual Clearance

The downward visual clearance is the solid angle bounded by the basic plane of the headform and a second plane tilted  $30^\circ$  down from the basic plane that intersects it at two points on the front surface of the headform that are 31 mm to the right and left of the

longitudinal plane as shown in figure 5. However, intrusions into this downward clearance are permitted so long as the intrusions are within the breath deflector allowance.

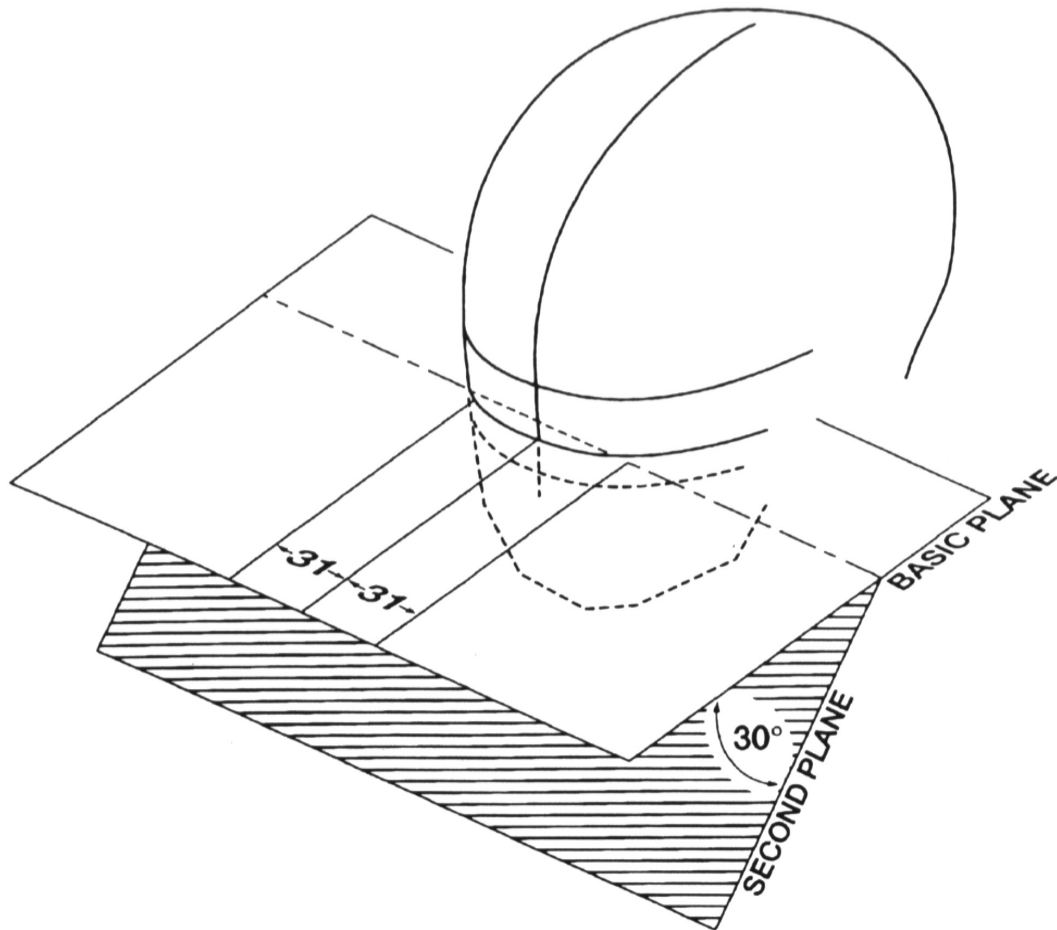

figure 5.

### Downward Visual Clearance

The breath deflector allowance is shown in figure 6. It includes the region that is within 31 mm to the right and left of the longitudinal plane and that lies below the two planes that form 45° with the longitudinal plane and that intersect it at the level of the S<sub>4</sub> plane.

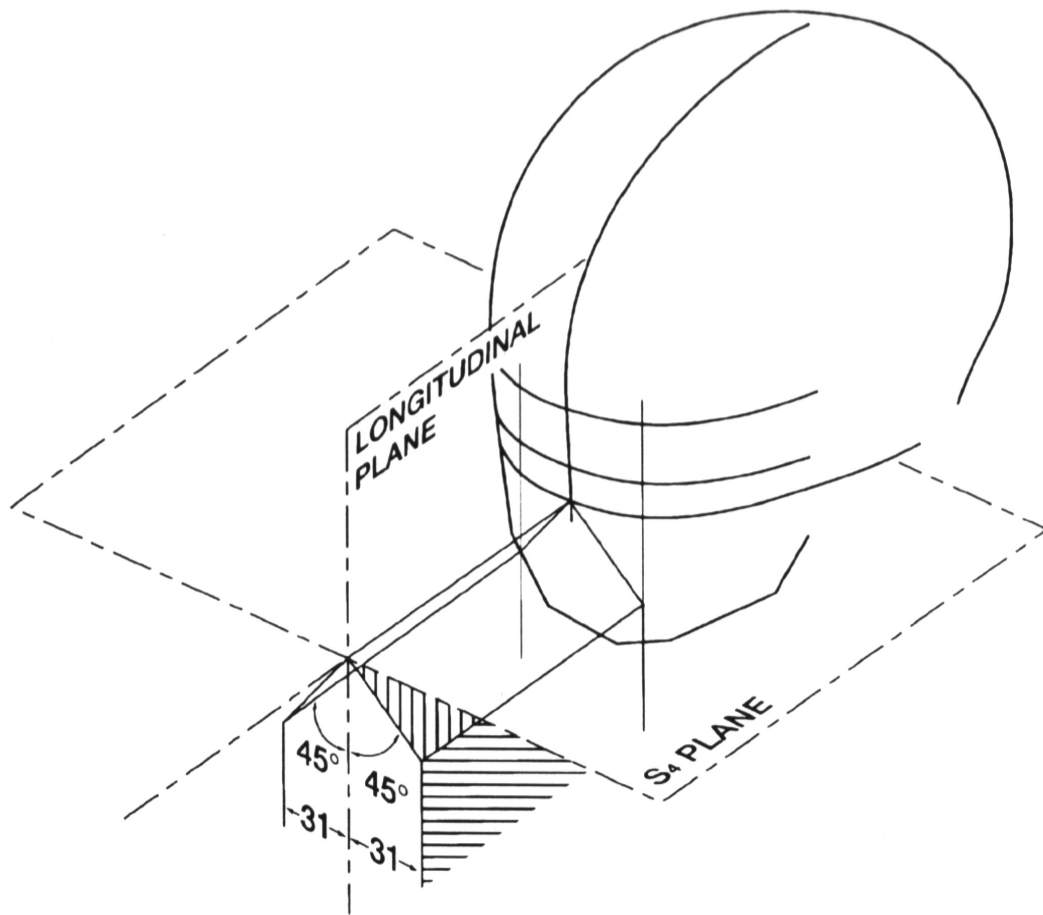

figure 6.

## Breath Deflector Allowance

### E. Performance Testing

The performance testing subjects helmets to a dynamic test of retention system strength, to a test for positional stability, to impact management tests, to helmet shell penetration tests, to a removability test, and to chin bar and face shield tests if appropriate. These tests are conducted upon helmet samples kept under laboratory ambient temperature and humidity or that have been conditioned in one of three environments simulating some of the conditions in which the helmet might reasonably be expected to be used.

Prior to conditioning and testing, samples may be exposed to solvents common to motorsports which have been found to attack and degrade some helmet components.



In certification testing, the first of the four samples is kept at laboratory ambient temperature and humidity and allowed to come to equilibrium. It is subjected first to the positional stability test and then to the impact management and other tests. The second, third and fourth samples are conditioned hot, cold and wet, respectively and subjected to the dynamic test of the retention system, the impact management test and the other tests.

The selection of tests, conditioning and special conditioning is left to the discretion of the Foundation's technical personnel. However, for certification testing, each of the specified tests shall be applied to at least one sample. Furthermore, it is expected that all testing will be conducted so as to exercise all the likely failure modes of the helmet.

### **E1. Conditioning for Testing**

Test samples may be kept at laboratory ambient temperature and humidity or may be conditioned either cold, hot or wet according to the specifications given below. At the discretion of the Foundation's technical personnel and at any point during the testing, a sample previously kept at ambient may be conditioned cold, hot or wet. However, once a sample has been conditioned cold, hot or wet, the sample must be maintained in that condition throughout the rest of the testing.

The special solvent wipe conditioning described below may be applied to any sample at the discretion of the Foundation's technical personnel.

**a. Special Conditioning.** Prior to any impact or retention system testing helmets may first be conditioned with a solvent mix of 50% toluene and 50% isooctane. A cotton cloth or suitable substitute shall be soaked in the solvent and used as an applicator. The solvent will be applied to the shell first in an area within 5 mm of the chinstrap attachments for not less than five (5) seconds on each side and then applied to the remainder of the shell for not

less than ten (10) seconds. At least thirty minutes shall elapse before further conditioning and testing.

**b. Cold.** The sample shall be conditioned by being exposed to a temperature of  $-20^{\circ}\text{C} \pm 2^{\circ}\text{C}$  for a period of not less than four (4) hours, nor more than twenty-four (24) hours.

**c. Heat.** The sample shall be conditioned by being exposed to a temperature of  $50^{\circ}\text{C} \pm 2^{\circ}\text{C}$  for a period of not less than four (4) hours, nor more than twenty-four (24) hours.

**d. Wet.** The sample shall be conditioned by being continuously sprayed with water at a temperature of  $25^{\circ}\text{C} \pm 5^{\circ}\text{C}$  for a period of not less than four (4) hours, nor more than twenty-four (24) hours. This spray shall be directed at the helmet's external surfaces. The helmet shall not be subjected to total immersion.

All testing of these hot, cold and wet helmets shall begin within two (2) minutes from the time of removal from the conditioning apparatus. The samples shall be returned to the conditioning apparatus between tests.

## **E2. Positional Stability (Roll-Off)**

The test for positional stability shall only be applied to samples kept at ambient laboratory temperature and humidity. The helmet shall not have been subjected to any prior performance testing.

The helmet shall be tested on the smallest appropriate standard full-face headform. The headform shall be supported on a stand so that its vertical axis points downward at an angle of  $135^{\circ}$  to the direction of gravity. The headform shall be oriented face down. The helmet shall be placed on the headform and adjusted to obtain the best configuration of the retention system. A wire rope shall be hooked to the edge of the helmet at the rear centerline and brought forward so that its free end hangs downward across the top of the helmet. An inertial hammer shall be suspended from the free end of the rope. This inertial

hammer shall enable a 4.0 kg  $\pm$  50 g mass to be dropped through a 0.6 m guided fall in order to deliver an abrupt shock load to the headgear. The shock load will force the helmet to rotate forward on the headform. The helmet may be shifted but must remain on the headform.

The headform shall be repositioned so that it is facing upward but with the vertical axis still oriented downward at 135° to gravity. The helmet shall be positioned and adjusted to obtain the best configuration of the retention system. The wire rope/inertial hammer shall be hooked to the brow edge of the helmet at the center line so that the rope lies along the centerline and the hammer is suspended from the top of the helmet. The shock weight shall be dropped through the 0.6 m guided fall delivering an abrupt shock load forcing the helmet to rotate rearward. The helmet may be shifted but must remain on the headform.

The inertial hammer shall be such that its mass is no more than 5.0 kg including the 4.0 kg shock mass.

### **E3. Dynamic Test of Retention System**

The dynamic test of the retention system may be applied to any sample either kept at ambient temperature and humidity or conditioned hot, cold or wet. This test may be performed before, after, or between any of the other procedures in the test sequence. However, the retention test shall not be valid if an integral chin bar has been removed from a full face helmet.

The helmet shall be placed on a headform in such a manner that the chin strap may be fastened under a device whose upper end approximates the contour of the bony structure of the jaw. The device will then be given a mechanical pre-load followed by a dynamic loading. The retention system fails if it cannot support the mechanical loads or if the maximum deflection during the dynamic load exceeds 30 mm. The retention system also fails if it cannot be easily and quickly unfastened after testing.

a. This chinstrap loading device shall consist of a simulated jaw and accommodations for the pre-load and dynamic load. The jaw portion shall consist of two metal bars or rollers, each one 12.7 mm ± 0.5 mm in diameter, separated by 76 mm ± 0.5 mm on center. The mass of this device shall not exceed 6.0 kg.

b. A pre-load shall be applied for at least 60 seconds. This pre-load plus the mass of the chinstrap loading device shall total 23 kg.

c. A 38 kg mass shall be dropped in a vertical guided fall a distance of 120 mm so as to load the retaining system abruptly; the 38 kg mass and pre-load mass shall not be additive. In order to protect the test mechanism, the impact of the 38 kg mass may be cushioned with a 00-93 durometer rubber pad 150 mm in diameter by 6½ mm thick, or its equivalent.

#### **E4. Impact management Tests**

The impact management tests may be performed on samples kept at ambient temperature and humidity or conditioned hot, cold or wet. The sample shall not have been subjected to the shell penetration test beforehand.

These tests involve a series of controlled impacts in which the helmet is positioned on a test headform. The helmeted headform is then dropped in guided falls onto specified test anvils. The impact site and the impact energy must meet certain requirements in order for the tests to be valid. If in a valid test, the peak acceleration imparted to the headform exceeds 300 G's, the helmet shall be rejected.

If the sample is so constructed that it interferes with the test equipment preventing impacts at sites within the test line, then, at the discretion of the Foundation's technical personnel, parts of the helmet may be cut away to facilitate testing. Every reasonable effort

to minimize such cutting will be made. However, there shall be no relaxation of the impact levels or of the test criteria.

Certain tests shall not be valid when performed on samples that have been cut for impact testing: the dynamic strength of retention system test of section E3., the positional stability test of section E2., the chin bar test of section E5. and the removability test of section E8.

#### **E4.1 Impact Management Test Equipment**

The test equipment shall consist of at least the following items:

**a.** The smallest of the headforms appropriate for the helmet sample. This headform shall be of rigid, low resonance metal such as magnesium alloy and shall conform to the 'A', 'E', 'J', 'M' or 'O' geometries specified in ISO DIS 6220-1983.

**b.** A ball-arm/collar assembly which is fitted to a socket machined into the base of the headform. The ball/socket configuration shall be such that the geometrical center of the ball is located on the central vertical axis of the headform 12.7 mm above the reference plane as described in ISO DIS 6220-1983. The ball-arm/collar assembly shall also include a uniaxial accelerometer fixed firmly into the ball.

**c.** A headform support assembly rigidly attached to the ball-arm. This support assembly shall be such that it and consequently the headform may be guided in a vertical drop. The weight of the support assembly shall not exceed 25% of the combined weights of the headform, ball-arm, collar and accelerometer. The total mass of the headform/support assembly shall not be less than 5.0 kg nor more than 6.5 kg.

**d.** A guidance system such that the headform/support assembly may be guided in vertical drop onto a test anvil. This guidance system may consist of two or more wires

or one or more rails. The headform/support - guidance system - test anvil alignment shall be such that:

**d1.** The drop trajectory shall be a straight line within  $3^\circ$  of vertical and within  $5^\circ$  of the sensitive axis of the uniaxial accelerometer.

**d2.** The line parallel to the drop trajectory and passing through the center of the headform ball-socket shall pass within 5 mm of the center of the test anvil, within 10 mm of the center of gravity of the headform/support assembly, and within 5 mm of the sensitive element of the uniaxial accelerometer.

**e.** A rigid anvil mount consisting of a solid mass of at least 135 kg. The upper surface of the anvil mount shall consist of a steel plate with a minimum thickness of 12 mm and a minimum surface area of  $0.10 \text{ m}^2$ .

**f.** Three test anvils : flat, hemispherical and edge.

**f1.** The flat anvil shall have a minimum surface area of  $0.0127 \text{ m}^2$ , e.g. 127 mm diameter face. When fixed in position on the anvil mount, the surface shall be perpendicular to the headform trajectory.

**f2.** The hemispherical anvil shall have a  $48 \text{ mm} \pm 0.5 \text{ mm}$  radius.

**f3.** The edge anvil shall have a striking face 6.3 mm wide by at least 180 mm long with a depth of at least 35 mm. When in position, the striking face shall be perpendicular to the headform trajectory.

**g.** A uniaxial accelerometer. The acceleration data channel must comply with SAE recommended practice J 211 requirements for channel class 1000 with the exception that the frequency response need not include the range from dc to 10 hz which may not be obtainable using certain types of transducers.

h. A velocity measurement device which will yield the velocity of the headform/support assembly within the last 40 mm of travel before impact. The velocity measurements must be accurate to within  $\pm 1\%$ .

#### **E4.2 Test Definitions**

a. The impact site refers to the portion of the helmet struck during an impact test. It is defined as the point where a line passing through the center of the headform ball and the center of the anvil intersects the outer surface of the helmet at the instant the helmet first touches the anvil.

b. The impact energy is the kinetic energy of the headform/support assembly at the instant of impact. It is defined as the mass of the headform/support assembly times the square of the velocity measurement times one half. The mass of the helmet is ignored in this calculation.

#### **E4.3 Test Impacts**

Test impact sites shall be on or above the test line. Rivets, vents and any other helmet feature within this region shall be valid test sites. Each impact site will be subjected to a group of one or two impacts according to the anvil selected for that site.

The impact site for the first impact within in a group is the target for the successive impacts. However, if an impact is sited closer than 120 mm to any previous impact not of its group, that later impact shall be declared invalid.

There is no restriction regarding test anvil selection. The impact energies for each test impact are as follows:

a. There shall be two impacts at each site tested against the flat anvil. For the first impact, the impact energy shall be 150 j for all testing regardless of headform size or weight. For the second impact, the impact energy shall be 110 j for all testing regardless of

headform size or weight. Given an ideal frictionless mechanical test facility, the certification impact energies represent 3.0+ meter and 2.2+ meter drops of a 5 kg headform and supporting assembly.

**b.** There shall be two impacts at each site tested against the hemispherical anvil. For the first impact, the impact energy shall be 150 j for all testing regardless of headform size or weight. For the second impact, the impact energy shall be 110 j for all testing regardless of headform size or weight. Given an ideal frictionless mechanical test facility, the impact energies represent 3.0+ meter and 2.2+ meter drops of a 5 kg headform and supporting assembly.

**c.** There shall be one impact at each site tested against the edge anvil. For each impact against the edge anvil, the impact energy shall be 150 j for all testing regardless of headform size or weight. Given an ideal frictionless mechanical test facility, this energy represents a 3.0+ meter drop of a 5 kg headform and supporting assembly.

**d.** If the impact energy for any test impact exceeds the energy specified by more than 3%, that impact shall be declared invalid.

#### **E4.4 Impact Test Interpretation**

The peak acceleration of the headform shall not exceed 300 G's for any valid test impact. Similarly, the helmet's protective structures shall remain intact throughout the testing. If, the Foundation's technical personnel conclude that the headgear has been compromised by breakage, the sample shall be rejected.

If, in certification testing, a sample is found to meet all the test criteria but any two of the impacts were at less than 97% of the impact energy specified, the testing for that sample shall be declared inconclusive and must be repeated. Similarly, if there are two instances where an impact falls beyond 10 mm from the first impacts in its group, the testing for the



sample shall be declared inconclusive and must be repeated. Finally, if an invalid impact produces a peak acceleration exceeding 300 G's, the testing for the sample shall be declared inconclusive and must be repeated.

The impact test procedures leave considerable latitude to the helmet tester regarding site and anvil selection. It is expected the tester will orchestrate each test series in order to investigate potential weaknesses and to exercise each likely failure mode.

If at the end of a certification test series, the Foundation's technical personnel conclude that the results obtained in valid impacts are not sufficient to determine whether the helmet model meets the performance requirements of this standard, additional samples may be conditioned and tested. It is expected that all samples submitted will meet all the test requirements.

#### **E5. Chin Bar Test**

The chin bar test applies to full face helmets only. At least one helmet in each certification series shall be tested. The helmet shall be firmly mounted on a rigid base so that the chin bar faces up and the reference plane is at  $65^{\circ} \pm 5^{\circ}$  from horizontal. A mass of  $5 \text{ kg} \pm .2 \text{ kg}$  with a flat striking face of  $0.01 \text{ m}^2$  minimum area shall be dropped in a guided fall so as to strike the central portion of the chin bar with an impact velocity of  $3.5 \text{ m/sec} \pm 0.2 \text{ m/sec}$ . The maximum downward deflection of the chin bar must not exceed 60 mm nor any component fail so as to cause a potential injury to the wearer.

#### **E6. Shell Penetration Test**

The complete helmet shall be placed on a rigidly mounted headform. If the helmet contains a sling or some other adjustable sizing component, it shall be relaxed to its most extendable position.

The penetration test striker shall have a mass of  $3 \text{ kg} \pm 50 \text{ g}$ . The striker shall fall through a height of  $3 \text{ m} \pm 15 \text{ mm}$ . The point of the striker shall be a cone with an included angle of  $60^\circ \pm 0.5^\circ$  and an altitude of  $38 \text{ mm} \pm 0.38 \text{ mm}$ . The striking tip shall have a hardness of 60 Rockwell (scale C  $\pm 3$  points) and a radius of  $.5 \text{ mm} \pm .01 \text{ mm}$ .

The test striker must not penetrate to achieve even momentary contact with the test headform.

#### **E7. Face Shield Penetration Test**

If a face shield is provided with a full face helmet, this face shield shall be tested for penetration resistance in the following manner:

The faceshield shall be tested on the appropriate helmet, correctly deployed across the facial opening and under laboratory ambient conditions. A sharp, soft lead pellet weighing  $1 \text{ gm} \pm 0.1 \text{ gm}$  with a diameter of  $5.5 \text{ mm} \pm 0.1 \text{ mm}$  and traveling at a velocity of  $500 \pm 20 \text{ km per hour}$  shall strike the face shield normal to the surface. The face shield shall be tested in at least three different locations: the center line and  $80 \text{ mm} \pm 5 \text{ mm}$  to either side of the center line. The pellet must not penetrate to the interior of the helmet.

#### **E8. Removability**

The helmet removability test determines whether the helmet can be removed from an unconscious victim without resorting to any buckles, clasps or other mechanisms which may be rendered non-functional by impact stresses. The helmet is placed on the largest appropriate complete ISO headform with all the closures and retention systems engaged. A technician must remove the helmet from the headform using simple, common hand tools but without accessing any of the helmet mechanisms.

The hand tools for this test are limited to shears, simple edged tools and flat bladed screw drivers. The operation must not require more than thirty seconds.